



Blow through unit coolers LEX

Standard coolers for cooling & freezing rooms





Contents

	pag.
Model indication.....	2
Eurovent	2
General information.....	3
Options & non-standard configuration.....	4
Fan data & defrost systems.....	5
Correction factors & selection examples.....	6
Capacities & technical data.....	7

Eurovent

Within Europe, a wide variety of published data on capacities are in use, generally depending on national standards. Most in use by the leading manufacturers are national and international standards like DIN, ENV, NEN-EN and ASHRAE. Due to this, customers have not been able to make objective product comparisons, since data published on capacities were based on DT_1 , DTM , dry or wet conditions, with or without certification, etc.



To meet the European requirements on EN standards, the European Refrigeration Industry embodied by Eurovent has set standards to guarantee an independent certification procedure for forced convection air cooled condensers based on NEN-EN 327 and unit air coolers based on NEN-EN 328. Being an active member of Eurovent, the capacities of the Helpman commercial cooler programme, as given in the technical documentation, are based on NEN-EN 328 (*evaporating temperature $t_0 = -8\text{ °C}$, 8 K temperature difference between air-on temperature and evaporating temperature (DT_1)*).

In order to enable air cooler selection for operating conditions, technical documentation should also give capacities for humid/frosted conditions. According to Eurovent these 'frosted conditions' are to be calculated by multiplying 'dry capacities' with a factor 1.15. These data can be found in the capacity tables, in the columns marked "frosted".

Model indication

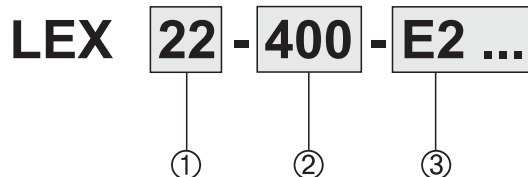

Pos.	Reference	Options
1	Cooler type	2 - 30
2	Current	400 = 230/400/50/3 230 = 230/50/1
3	Options	For a full survey of all available options see page 4.

Capacities

Frosted conditions

- Lightly frosted coil.
- Relative humidity 85 %.
- Suction gas superheating 62% of the temperature difference (DT_1), with a minimum of 3.5 K.
- Refrigerant liquid temperature 30 °C (for $t_0 = -20\text{ °C}$ and below: liquid temperature 10 °C).

Evaporating temperature t_0

Evaporating temperature t_0 is the saturated temperature according to the pressure at the suction outlet of the cooler.

Dry conditions

Cooling capacity where no condensation or ice build-up occurs on the coil (100% sensible cooling). This condition is used by Eurovent to standardise capacity ratings but should not be used when selecting coolers.

For cooler selection use the columns marked "frosted".



General information

LEX coolers are blow through unit coolers for application in cooling and freezing rooms for the temperature area +5 °C up to -40 °C. The air coolers are suitable for all halocarbon refrigerants.

Capacity range (Eurovent SC2) 1.3 to 40.1 kW.

Air flow 1080 up to 26000 m³/h.



PED

All coolers and condensers produced by Helpman comply with the Pressure Equipment Directive 97/23/EC. In this respect all equipment is provided with extensive product information. PED certificates may be downloaded from www.helpman.com (standard products only).

Two-Year Guarantee

Because Helpman has the fullest confidence in the product quality, a two-year full guarantee is given.

Other air cooler models

Based upon the same coil configuration as the LEX range Helpman supplies the following air cooler models:



PX
Low silhouette unit coolers
(brochure 50.03)



PLV
Mini air coolers
(brochure 50.04)



LDX
Dual discharge air coolers
(brochure 55.07)



LFX
Agricultural storage coolers
(brochure 55.15)

Productconfiguration LEX

- Coil
 - Copper Ripple Fin® tubing ø 2"
 - Tube centres 38 x 38 mm square pitch
 - Aluminium fins
 - Fin spacing 7 mm.
 - Coils are pressure tested with dry air at 36 bar.
- 1- 4 Fans, blowing through the coil, diameters 254 up to 508 mm. Fan motors protection class IP55.
- Eflo® refrigerant circuiting for higher effective cooling capacity.
- Durable aluminium casing, white epoxy coated (RAL 9003).
- Models up to LEX 12 fitted with hinged interchangeable side plates. Bigger models fitted with easy removable side plates.
- All models equipped with splash guard.
- Optimized refrigerant circuiting.
- Refrigerant connections on right hand side (fan side view).
- Equipped with a schröder valve on the suction connection for testing purposes.
- Sufficient room for fitting the expansion valve inside.
- Standard suitable for dry expansion (DX system). All models available on request for pumped circulation and glycol.
- Stickers indicate fan direction and refrigerant in/out.
- Heavy duty packing in wooden crates. LEX 18 and up delivered on wooden beams in mounting position. Installation can take place using a forklift.

Blow Through Unit Coolers

LEX



Options

■ **Defrost systems**

- Electric defrost

E2

■ **Fan ring heater**

FRH

Fan ring heater (230 Volt)

Incl. mounting gear		
LEX type	Fan diameter mm	Ring heater power Watt
14, 20	406	400
16, 22, 26	457	450
24, 28, 30	508	500

■ **Isolating switch (mounted)**

ISM

Non-standard executions *(on request only)*

■ **Special fan motors:**

- Single phase/three phase motors
- Traploos regelbare motoren
- 60 Hz models on request
- Increased external pressure

■ **Defrost systems**

- Hot gas coil in drip tray

G1

Eflo refrigerant circuiting

The optimal use of the available heat exchanging surface by means of "EFLO" liquid distributions system is based on two principles:



- The refrigerant is evaporating through the coil in parallel flow with the air.
- Superheating takes place on the air-inlet side, in the area with the highest tube temperature.

With Eflo, the cooling performance improves as a result of:

- Even frost formation over the coil.
- Prolongued cooling cycle, therefore a higher effective cooling capacity.
- Shorter defrost cycle.

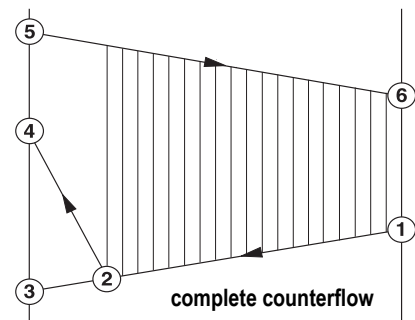
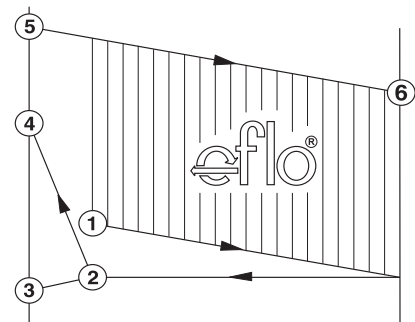

- 1) Refrigerant inlet temperature
- 2) Beginning of superheating refrigerant vapour
- 3) Evaporating temperature (t_0) corresponding with the pressure at the outlet of the cooler
- 4) Superheating temperature
- 5) Air-inlet temperature
- 6) Air-outlet temperature

Blow Through Unit Coolers

LEX



Defrost Systems

Two forced defrost designs are available for LEX coolers : hot gas defrost and electric defrost. Each defrost system is optimised for specific applications and ambient conditions.

Electric defrost E2

Stainless steel heater elements placed in additional tubes between the evaporator tubes. The elements for the driptray are fitted to the bottom of the inner tray.

Both coil and driptray have the same elements. Standard voltage per element 230 V.

Connection to 230 V / 1 phase or 400 V / 3 phase, connected in star with Zero-Wire. Total defrost power is given for 400 V / 3 phase with Zero-Wire.

All elements can be withdrawn at the refrigerant connection side. The driptray elements can be taken out after removal of the outer tray. The heater elements are pre-wired and are connected to one or more terminal boxes.

The following electric defrost system is available for LEX coolers:

E2 *Air on temperature down to - 25 °C.*
Electric stainless steel defrost elements in coil block and driptray.

Defrost power

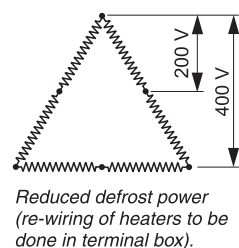
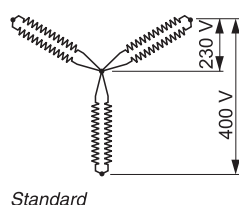

Electrical defrost E2

Cooler-model	number of elements		defrost power kW	
	coil block	driptray	standard	reduced
LEX 2	1	1	1.28	-
LEX 4	2	1	2.64	-
LEX 6	2	1	2.64	-
LEX 8	2	1	3.00	-
LEX 10	2	1	4.80	-
LEX 12	2	1	4.80	-
LEX 14	5	1	4.90	3.7
LEX 16	5	1	5.62	4.2
LEX 18	5	1	8.34	6.3
LEX 20	5	1	8.40	6.3
LEX 22	5	1	11.1	8.3
LEX 24	5	1	11.1	8.3
LEX 26	5	1	19.2	14.4
LEX 28	5	1	19.2	14.4
LEX 30	5	1	22.2	16.7

Hot Gas Defrost G1 *(on request only)*

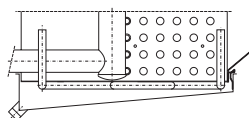

The driptray can be fitted with a copper defrost coil to bring it rapidly up to temperature by means of hot gas. This system may be applied to air on temperatures down to -5 °C.

Fans

Fans are executed with balanced aluminium or polyamide fan blades, fitted with robust electrolytically galvanized and epoxy coated fan guards according to DIN 31001. Fans are mounted in vibration dampers.

Enclosed design spray-tight motors, protection class IP-55. Motor windings suitable for 230 Volt.

All motors are equipped with a thermal safety device built in the windings, connected to separate terminals in the box.

This safety device can therefore be integrated into the control circuit. The electrical control should be arranged preferably with a manual reset device in order to prevent continuous on/off switching (tripping) of the motors.

Thermal safety device values (A)

Fan motor	Temperature °C			
	+10	0	-20	-40
230 / 50 / 1				
30 W	0.5	0.5	0.6	0.6
70 W	1.2	1.2	1.3	1.4
220 W	2.5	2.6	2.8	2.9
370 W	3.5	3.7	4.0	-
230 / 400 / 50 / 3				
30 W	0.3	0.3	0.3	0.3
90 W	0.5	0.5	0.6	0.6
250 W	1.1	1.1	1.1	1.2
370 W	1.4	1.4	1.4	1.5

Air throw

The throws as given in the tables are for veiling mounted coolers at t = 20 °C, an unrestrained air flow in the cold room and a minimal air velocity of 0.25 m/s at air throw distance.

Sound pressure dB(A)

Sound pressure as given in the tables are sound pressure levels in dB(A) at 5 m distance in free field conditions. Values may deviate depending on situations at site. The table below gives calculated sound pressure corrections at various distances.

Distance m	Correction dB(A)
1	+ 14
2	+ 8
3	+ 4
4	+ 2
5	0
10	- 6
20	-12
50	-20

Blow Through Unit Coolers

LEX

Selection Example DT₁

Refrigerant	R-404A dx
Required cooling capacity	6.8 kW
Air-on temperature	-16 °C
Evaporating temperature	-25 °C

- 1) $DT_1 = -16 - (-25) = 9 \text{ K}$
- 2) Correction factor $DT_1/R-404A : 1.06$
- 3) Multiply required capacity
with correction factor: $6.8 \times 1.06 = 7.2 \text{ kW}$.
- 4) Cooler models can be selected
in columns "capacity / frosted"
on page 7 with a nominal
capacity of 7.2 kW.

For the above mentioned conditions the following models can be selected:

- LEX 14, nom. cap. 5.9 kW.
- LEX 16, nom. cap. 7.9 kW.

Depending on parameters such as *air flow*, *number of fans* and *dimensions* (see tables) a final cooler model selection can take place.

Capacity values under "dry conditions" are reference values for Eurovent conditions.

Standard-condition	Air on temp. °C	Evaporating temperature °C	Factor dry/frosted
SC1	10	0	1.35
SC2	0	-8	1.15
SC3	-18	-25	1.05
SC4	-25	-31	1.00

SC 2 : Nominal capacity for cooling design.

Air-on temperature is the air temperature at the intake side of the coil block.

Correction factors

DT ₁ K	Evaporating temperature °C									
	+5	0	-5	-8	-10	-15	-20	-25	-30	-35
R-404A & R-507 dx										
6	1.28	1.32	1.38		1.44	1.51	1.58	1.64	1.69	1.72
7	1.06	1.10	1.15		1.20	1.27	1.33	1.39	1.44	1.48
8	0.89	0.93	0.97	1.00	1.03	1.09	1.15	1.21	1.26	1.29
9	0.77	0.80	0.84		0.89	0.95	1.00	1.06	1.11	1.15
10	0.67	0.70	0.74		0.78	0.83	0.89	0.95	1.00	1.04
11	0.59	0.62	0.65		0.70	0.74	0.80	0.85	0.90	0.94
R-134a dx										
6	1.34	1.42	1.50		1.60	1.71	1.82	1.94		
7	1.11	1.17	1.25		1.34	1.43	1.54	1.64		
8	0.94	0.99	1.06		1.14	1.23	1.32	1.42		
9	0.81	0.86	0.92		0.99	1.07	1.16	1.25		
10	0.70	0.75	0.80		0.87	0.94	1.03	1.11		
11	0.62	0.66	0.71		0.77	0.84	0.92	1.00		
R-22 dx										
6	1.34	1.39	1.45		1.52	1.59	1.66	1.73	1.78	1.81
7	1.11	1.15	1.21		1.27	1.33	1.40	1.47	1.52	1.55
8	0.94	0.98	1.03		1.08	1.14	1.21	1.27	1.32	1.36
9	0.81	0.84	0.89		0.94	1.00	1.06	1.12	1.17	1.21
10	0.70	0.74	0.78		0.82	0.88	0.94	1.00	1.05	1.09
11	0.62	0.65	0.69		0.73	0.78	0.84	0.90	0.95	0.99
R-404A & R-507A pumped system										
6	1.00	1.07	1.13		1.19	1.24	1.29	1.34	1.39	1.44
7	0.82	0.88	0.94		1.00	1.05	1.10	1.15	1.20	1.25
8	0.70	0.75	0.80		0.85	0.90	0.95	1.00	1.05	1.11
9	0.60	0.65	0.69		0.74	0.79	0.84	0.89	0.94	1.00
10	0.52	0.56	0.61		0.65	0.70	0.75	0.80	0.85	0.91
11	0.46	0.50	0.54		0.58	0.62	0.67	0.72	0.78	0.84
R-22 pumped system										
6	1.13	1.21	1.28		1.34	1.39	1.44	1.48	1.53	1.58
7	0.92	0.98	1.05		1.10	1.16	1.21	1.25	1.30	1.36
8	0.76	0.82	0.88		0.93	0.98	1.03	1.08	1.14	1.20
9	0.64	0.70	0.75		0.80	0.85	0.90	0.95	1.01	1.07
10	0.55	0.60	0.65		0.70	0.74	0.79	0.84	0.90	0.97
11	0.48	0.52	0.57		0.61	0.66	0.71	0.76	0.82	0.89

Correction factors for other refrigerants on request.

Blow Through Unit Coolers

LEX

Capacities & technical data

Cooler model	Capacities R404A / R507A (kW)		Air-flow m ³ /h	Coil surface m ²	Int. vol. dm ³	Weight kg	Fans						
	Frosted $t_0=-8^{\circ}\text{C}$ $DT_i=8\text{K}$	Dry $t_0=-8^{\circ}\text{C}$ $DT_i=8\text{K}$					Number	Diam. mm	Capacity W nom./absorbed*	Air throw m	Sound pressure dB(A)	Cable inlet	
LEX 2	1.3	1.2	1080	4.7	2.1	17	1	254	30/80	30/65	10	48	2 x M20 x 1.5
LEX 4	1.9	1.7	1840	6.7	3.0	21	1	305	70/190	90/190	12	50	2 x M20 x 1.5
LEX 6	2.8	2.4	1750	10.1	4.0	25	1	305	70/190	90/190	12	50	2 x M20 x 1.5
LEX 8	4.4	3.8	2800	15.7	6.0	35	1	356	70/190	90/190	15	53	2 x M20 x 1.5
LEX 10	4.1	3.6	3680	13.5	6.0	32	2	305	70/190	90/190	15	53	2 x M20 x 1.5
LEX 12	5.5	4.8	3500	20.2	6.8	38	2	305	70/190	90/190	15	53	2 x M20 x 1.5
LEX 14	5.9	5.1	3900	21.2	8.0	46	1	406	220/380	250/400	15	57	2 x M20 x 1.5
LEX 16	7.9	6.9	5100	27.9	10.4	61	1	457	220/380	250/400	20	60	2 x M20 x 1.5
LEX 18	9.0	7.8	5600	31.4	11.6	65	2	356	70/190	90/190	20	56	2 x M20 x 1.5
LEX 20	12.2	10.6	7800	42.4	15.5	88	2	406	220/380	250/400	20	60	2 x M20 x 1.5
LEX 22	15.7	13.7	10200	55.9	20.4	111	2	457	220/380	250/400	20	63	2 x M20 x 1.5
LEX 24	20.0	17.4	13000	69.8	28.2	128	2	508	370/500**	370/500	20	66	2 x M20 x 1.5
LEX 26	24.6	21.4	15300	84.2	30.9	159	3	457	220/380	250/400	20	65	2 x M20 x 1.5
LEX 28	31.0	27.0	19500	105.2	39.8	186	3	508	370/500**	370/500	20	68	2 x M20 x 1.5
LEX 30	40.1	34.9	26000	140.1	51.1	256	4	508	370/500**	370/500	20	69	2 x M20 x 1.5

* Fan power is given per motor. Absorbed fan power is measured with coil face area blocked for 75% and ambient temperature of 20 °C

** These motors are suitable for temperatures down to -20 °C and are NOT provided with a thermal safety device in the windings.

Dimensions

Cooler type	Dimensions mm							Refrig. conn.	
	A	B	D	F	G	H	K	inlet OD	suction* ODS
LEX 2	598	412	470	365	-	360	380	1/2"	1/2"
LEX 4	658	472	500	395	-	430	440	1/2"	1/2"
LEX 6	658	472	630	503	-	430	440	1/2"	e"
LEX 8	788	602	640	503	-	505	570	1/2"	22 mm
LEX 10	1106	920	500	395	-	430	880	1/2"	e" mm
LEX 12	1106	920	630	503	-	430	880	1/2"	22 mm
LEX 14	970	692	670	520	60	620	660	1/2"	22 mm
LEX 16	1110	792	720	520	45	700	760	1/2"	22 mm
LEX 18	1460	1180	650	500	40	540	1140	1/2"	35 mm
LEX 20	1640	1360	670	520	60	620	1320	e"	35 mm
LEX 22	1880	1560	720	520	100	700	1520	e"	42 mm
LEX 24	1880	1560	820	630	120	850	1520	e"	42 mm
LEX 26	2650	2328	720	520	100	700	2290	e"	54 mm
LEX 28	2650	2328	820	630	120	850	2290	e"	54 mm
LEX 30*	3420	3098	820	630	120	850	3050	e"	54 mm

* LEX 30: 3 mounting channels, distance 2 B (1549 mm)

2 water drains, 1" BSP male, distance 1700 mm

LEX 2 - 12

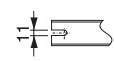
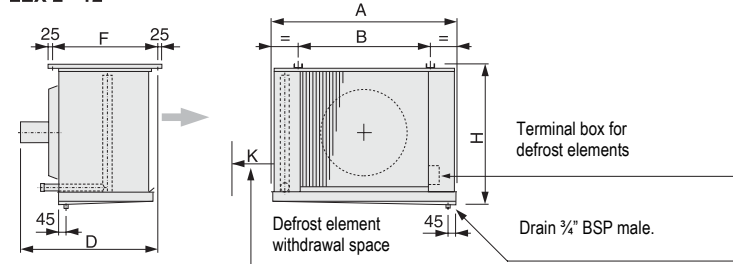

LEX 14 - 30

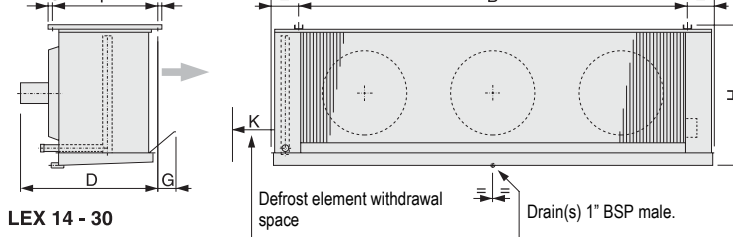

Alfa Laval in brief

Alfa Laval is a leading global provider of specialized products and engineered solutions.

Our equipment, systems and services are dedicated to helping customers to optimize the performance of their processes. Time and time again.

We help our customers to heat, cool, separate and transport products such as oil, water, chemicals, beverages, foodstuffs, starch and pharmaceuticals.

Our worldwide organization works closely with customers in almost 100 countries to help them stay ahead.

How to contact Alfa Laval

Up-to-date Alfa Laval contact details for all countries are always available on our website at www.alfalaval.com

Helpman products

Helpman, a well respected air heat exchanger manufacturer, was acquired by Alfa Laval in 2007. The Helpman brand will remain as a strong product name.

Information about Alfa Laval Helpman products is available on the website www.helpman.com.

